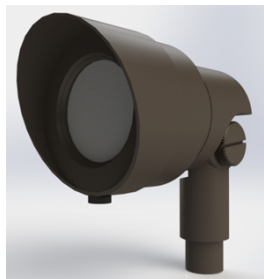
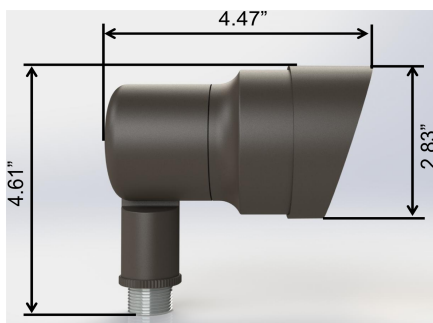

PRODUCT IMAGES

Standard Dimensions:

Features:

- Professional grade die cast aluminum construction with powder coat finish for exceptional durability
- High quality optics available in various lumen outputs and beam angles for superior illumination
- Fully sealed housing designed to prevent water ingress with IP66 rating
- Advanced Voltage Surge Suppression for protection from lightning strikes
- Toolless adjustment of cowl and installation angle

Performance:

Output	300 Lumen	450 Lumen
Color Temperature	3000K	3000K
Input Voltage	9-15VAC	9-15VAC
Wattage	3W	3W
Input Current	0.6A@12.1VAC	0.6A@12.1VAC
Efficacy (LM/W)	46	46
Power Factor	0.7	0.7
Halogen Replacement	50W	50W

Environmental:

Environmental Protection Rating	IP66 Wet
Ambient Operating Range	-25°C to 40°C
Storage Temperature Range	-25°C to 40°C
Expected Life	50K Hours > 75°C Tc Max

Included Accessories:

- Adjustable Cowl (Accepts 1 additional filter media)
- 40" Lead Wire and direct burial gel filled wire nuts
- Installation Stake

Warranty:

- Standard 10 Year Warranty
- See www.lumenscapeltg.com/warranty for details.

ORDERING INFORMATION

ORDERING EXAMPLE: AC30LSP15AZT